

Aerovox[®]

Power Factor Correction Capacitors

SINGLE- AND THREE-PHASE
PFC CAPACITORS FOR HIGH
RELIABILITY APPLICATIONS



Intelligent Capacitor Solutions



AeroPower™ power factor correction capacitors are constructed using high quality materials and Lean Six Sigma manufacturing practices to provide reliable performance and long life during continuous use.

Aerovox capacitors undergo 100% electrical testing to further ensure high level performance. If you have specialized needs, our flexible manufacturing processes allow us to quickly provide custom configurations.



CONTENTS

General Information	2
Construction.....	4
Harmonic Distortion	4
Cover Terminals.....	5
Specifications: AMP0, MMP0 and EPFC Capacitors	6
Safety Features	8
Mounting Orientation.....	8
Part Numbering System.....	8
Ratings Tables & Drawings: AMP0, MMP0 and EPFC Capacitors.....	9
Equations for Reactive Compensation and Harmonic Distortion.....	18

Aerovox provides intelligent capacitor solutions.



Power Factor Correction Capacitors

SINGLE- AND THREE-PHASE PFC CAPACITORS FOR HIGH RELIABILITY APPLICATIONS



Aerovox manufactures both single- and three-phase power factor correction capacitors up to 4,800 VAC. Our AeroPower brand PFC capacitors are designed for high reliability applications, and have a life rating of over 200,000 hours. They are manufactured to withstand harmonic currents, with special high harmonic versions available.

Three types of standard reactive compensation capacitors are available:

- AMP0: Vacuum-impregnated metallized polypropylene, compact size. Available in both oil-filled and dry configurations. (Made in USA)
- MMP0: Vacuum-impregnated metallized polypropylene, rugged welded case. (Made in USA)
- EPFC: Euro-style vacuum-impregnated metallized polypropylene, round aluminum studded case (Made in China)

Highlights

- Both European and North American styles available
- Long life
- Over-current rating to 150%
- Over-voltage rating to 120%
- Includes discharge resistors
- Large 325 KVAR capacitors available
- Single and three phase
- Loss of KVAR/fault detection



Specifications

Capacitance Range:	0.5 to 325 KVAR
Capacitance Tolerance:	0 to +15%
AC Voltage Range:	240 VAC to 4,800 VAC; single- or three-phase
Rated Frequency:	50 or 60 Hz
Capacitor Connection:	3-phase, internal delta connection standard; wye available on request
Operating Life:	>200,000 hours
Total Losses:	<0.5 Watts / KVAR at 60 Hertz, 25°C
Operating Temperature Range:	-40°C to +46°C
Approval Certification:	UL, cUL (≤600 VAC)

Applications

- Power factor correction systems
- Harmonic Filters
- Alternative energy power systems
- Induction heating capacitor alternatives

Power Factor Correction Capacitors

SINGLE- AND THREE-PHASE PFC CAPACITORS
FOR HIGH RELIABILITY APPLICATIONS

Standard Voltage and KVAR Ratings at 60 Hertz*

LOW VOLTAGE	AMP0	EPFC	MMP0
240 VAC	0.5–10	0.5–10	20–30
480 VAC	0.5–25	2–40	25–100
600 VAC	1.0–25	10–40	25–100
750 VAC	–	–	25–150

MEDIUM VOLTAGE	MMP0
900 VAC	25–150
1040 VAC	25–240
1200 VAC	25–240
2400 VAC	25–300
2770 VAC	25–300
4160 VAC	25–300
4800 VAC	25–325

Construction

All AeroPower capacitors are impregnated with a dielectric fluid to give added insulation, excellent corona protection and a moisture barrier. The dielectric fluid is considered a green (benign), environmentally friendly material. MMP0 and EPFC capacitors are 100% leak tested. Aerovox products do not contain PCBs.

*Please consult the factory for other voltages, frequencies and KVAR ratings.

Harmonic Distortion

Harmonic distortion is the resulting non-sinusoidal current waveform generated by a non-linear load. The most common non-linear load is a pulse rectifier, which is used in most switch mode power supplies, variable speed drives and uninterruptible power supplies. The distorted current waveform generates a distorted source voltage due to the system (electrical power system) impedance. A distorted waveform can be analyzed by decomposing it into a fundamental component (line frequency) and higher frequency components of varying amplitude.

The effects of harmonic distortion on metallized film capacitors are (1) higher operating temperature because of higher I²R losses, and (2) higher voltage stress on the dielectric. Both of these factors will shorten the life of a capacitor dramatically.

All Aerovox Power Factor Correction capacitors are designed to handle harmonic currents, however, Aerovox also offers capacitors that are custom designed for systems with high harmonic distortion. By using our high-harmonic capacitors in your harmonic rich application, you will have a more robust construction compared to using standard capacitors in the same application.

Power Factor Correction Capacitors

SINGLE- AND THREE-PHASE PFC CAPACITORS
FOR HIGH RELIABILITY APPLICATIONS

Cover Terminals

Most AMP0 and low voltage MMP0 cells are available either in three or five terminal configurations, specified by KVAR rating (see individual specifications). The medium voltage and EPFC cells are not available with 5 terminals. The internal schematics for these terminal configurations are shown in Figures 1A and 1B. The standard five terminal designs can be connected with external components, as shown in Figures 2 and 3, to obtain a loss-of-KVAR feature. In this configuration, a neon indicator lamp will illuminate during a loss-of-fuse or a loss-of-capacitance condition.

Figure 1A: AMP0 & Low Voltage MMP0

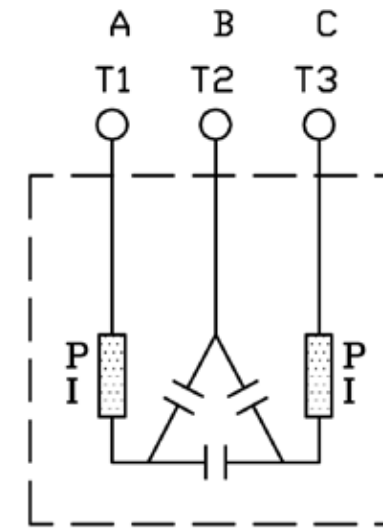
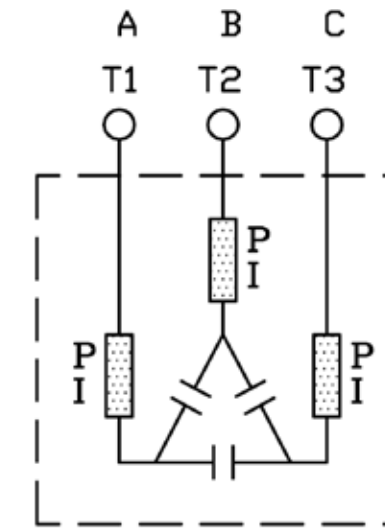
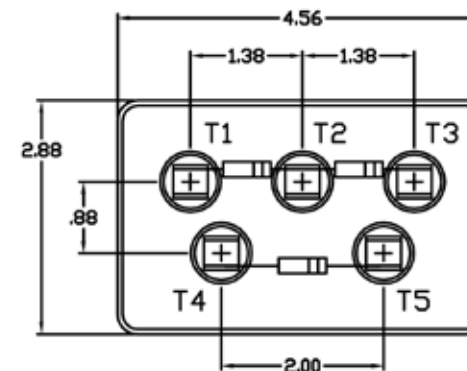

Figure 1B: EPFC



Internal Schematics for Low Voltage
Three-Terminal Capacitors

Figure 2



External Setup for
Five Terminal AMP0 Capacitors

Figure 3

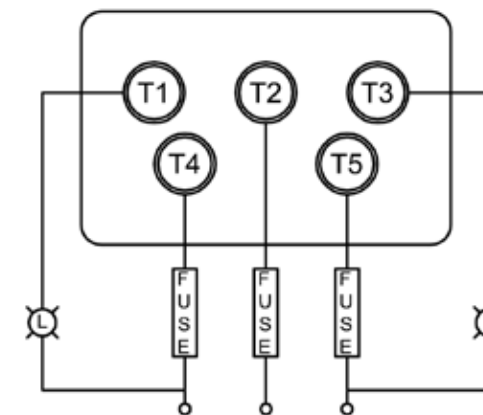

External Connections for Loss
of KVAR Option

Power Factor Correction Capacitors

SINGLE- AND THREE-PHASE PFC CAPACITORS
FOR HIGH RELIABILITY APPLICATIONS

Reactive Power Compensation Capacitor Specifications

	AMP0 Low Voltage (Three-phase and single-phase)	MMP0 Low Voltage (Three-phase and single-phase)	MMP0 Low Voltage (Three-phase and single- phase)	MMP0 Medium Voltage 1040 to 4800 VAC (Three-phase and single-phase)	EPFC Low Voltage (Three-phase)
--	---	---	--	--	-----------------------------------

Electrical Characteristics

Rated Voltages	240, 480 and 600 VAC	240, 480 and 600 VAC	750 and 900 VAC	1040, 1200, 2400, 2770, 4160 and 4800 VAC	240, 480 and 600 VAC
Rated Frequency	60 Hertz	60 Hertz	60 Hertz	60 Hertz	60 Hertz
Capacitor Type	Fluid impregnated (Dry also available)	Fluid impregnated	Fluid impregnated	Fluid impregnated	Fluid impregnated
Dielectric System	Self-healing metallized polypropylene film	Self-healing metallized polypropylene film	Self-healing metallized polypropylene film	Self-healing metallized polypropylene film	Self-healing metallized polypropylene film
Impregnation Fluid	Non-PCB, non-toxic, biodegradable, Class III combustible fluid	Non-PCB, non-toxic, biodegradable, Class III combustible fluid	Non-PCB, non-toxic, biodegradable, Class III combustible fluid	Non-PCB, non-toxic, biodegradable, Class III combustible fluid	Non-PCB, non-toxic, biodegradable, Class III combustible fluid
Capacitor Connecton, 3-phase	Internal delta connection	Internal delta connection	Internal wye connection	Internal delta or wye connection	Internal delta connection
Capacitance Tolerance	-0% to +15%	-0% to +15%	-0% to +15%	-0% to +15%	-0% to +15%
Discharge Device	External resistors reduce residual voltage to <50 V with in 1 minute	Internal resistors reduce residual voltage to <50 V within 1 minute	Internal resistors reduce residual voltage to <50 V within 5 minutes	Internal resistors reduce residual voltage to <50 V within 5 minutes	External resistors reduce residual voltage to <50 V within 1 minute
Total Losses	<0.5 Watts / KVAR at 60 Hertz, 25°C	<0.5 Watts / KVAR at 60 Hertz, 25°C	<0.5 Watts / KVAR at 60 Hertz, 25°C	<0.5 Watts / KVAR at 60 Hertz, 25°C	<0.5 Watts / KVAR at 60 Hertz, 25°C (without resistors)
Design Service Life	200,000 hours continuous duty	200,000 hours continuous duty	200,000 hours continuous duty	20 years continuous duty	200,000 hours continuous duty

Over Current

Standard	135% * rated current continuous, includes harmonic currents	135% * rated current continuous, includes harmonic currents	135% * rated current continuous, includes harmonic currents	135% * rated current continuous, includes harmonic currents	135% * rated current continuous, includes harmonic currents
High Harmonic	150% * rated current continuous, includes harmonic currents	150% * rated current continuous, includes harmonic currents	150% * rated current continuous, includes harmonic currents	150% * rated current continuous, includes harmonic currents	150% * rated current continuous, includes harmonic currents

Over Voltage

Standard	110% * rated voltage continuous	110% * rated voltage continuous	110% * rated voltage continuous	110% * rated voltage continuous	110% * rated voltage continuous
High Harmonic	120% * rated voltage continuous	120% * rated voltage continuous	120% * rated voltage continuous	120% * rated voltage continuous	120% * rated voltage continuous

Power Factor Correction Capacitors

SINGLE- AND THREE-PHASE PFC CAPACITORS
FOR HIGH RELIABILITY APPLICATIONS

	AMP0 Low Voltage (Three-phase and single-phase)	MMP0 Low Voltage (Three-phase and single-phase)	MMP0 Low Voltage (Three-phase and single- phase)	MMP0 Medium Voltage 1040 to 4800 VAC (Three-phase and single-phase)	EPFC Low Voltage (Three-phase)
--	---	---	--	--	-----------------------------------

Mechanical Characteristics

Enclosure Type	Drawn tin plated steel rectangular can	Heavy gauge welded steel construction	Heavy gauge welded steel construction	Heavy gauge welded steel construction	Extruded aluminum cylindrical can with M12 ground stud
Finish	None (standard) Painted (optional)	Light gray paint, ANSI #61, UL approved for outdoor usage	Light gray paint, ANSI #61, UL approved for outdoor usage	Light gray paint, ANSI #61, UL approved for outdoor usage	None
Mounting	Optional bracketing is available	Heavy gauge brackets, mounting holes 2 x 1/2 x 5/8" slots	Heavy gauge brackets, mounting holes 2 x 1/2 x 5/8" slots	Heavy gauge brackets, mounting holes 2 x 1/2 x 5/8" slots	M12 Mounting stud
Terminals	5 terminal cover: 1/4" male quick connect 3 and 2 terminal cover: 1/4"-20 male threaded stud, 20 In-lbs max. fastening torque	1/2"-13 brass studs, 160 in/lbs fastening torque, 30 kV BIL bushing	1/2"-13 brass studs, 160 in/lbs fastening torque, 30 kV BIL bushing	1/2"-13 brass studs, 160 in/lbs fastening torque, 60 kV BIL ceramic bushings	Three (3) contact terminal contact block
Loss of KVAR feature	Standard with 5 terminal cover only	Optional	Optional	-	-

Environmental Characteristics

Operating Temperature	-40°C to + 46°C, -40°F to + 115°F, with natural convection cooling	-40°C to + 46°C, -40°F to + 115°F, with natural convection cooling	-40°C to + 46°C, -40°F to + 115°F, with natural convection cooling	40°C to + 46°C, -40°F to + 115°F, with natural convection cooling	-40°C to + 46°C, -40°F to + 115°F, with natural convection cooling
Storage Temperature	-40°C to + 85°C, -40°F to +185°F	-40°C to + 85°C, -40°F to +185°F	-40°C to + 85°C, -40°F to +185°F	-40°C to + 85°C, -40°F to +185°F	-40°C to + 85°C, -40°F to +185°F
Maximum Altitude	2000 meters above sea level	2000 meters above sea level	2000 meters above sea level	2000 meters above sea level	2000 meters above sea level
Humidity	0 to 95% non-condensing	0 to 95% non-condensing	0 to 95% non-condensing	0 to 95% non-condensing	0 to 95% non-condensing
Standards	UL 810 UL C22.2 No. 190 Canadian Standards IEC 831	UL 810 UL C22.2 No. 190 Canadian Standards ANSI/IEEE 18 NEMA CP-1 IEC 831	ANSI/IEEE 18 NEMA CP-1 IEC 831	ANSI/IEEE 18 NEMA CP-1 IEC 871-1	UL 810 IEC 60831
Certifications	UL Recognized CYTW2 cUL Recognized CYTW8 RoHS Compliant	UL Recognized CYTW2 cUL Recognized CYTW8	-	-	UL Recognized CYTW2 cUL Recognized CYTW8
Safety Features	Pressure interrupter Self-healing technology External discharge resistors	Pressure interrupter Self-healing technology Internal discharge resistors	Pressure interrupter Self-healing technology Internal discharge resistors	Self-healing technology Internal discharge resistors	Pressure interrupter Self-healing technology External discharge resistors

Power Factor Correction Capacitors

SINGLE- AND THREE-PHASE PFC CAPACITORS FOR HIGH RELIABILITY APPLICATIONS

Safety Features

Discharge resistors are placed internally on MMP0 and externally on AMP0 and EPFC capacitor cells. The resistors are a safety feature that drains the voltage on the terminals once the unit is taken offline to less than 50 volts in one minute or less for cells rated up to 600 VAC or in 5 minutes or less for cells rated over 600 VAC. The resistors are sized for long life continuous operation at maximum-rated temperature.

Aerovox low-voltage capacitor cells have UL and cUL recognized pressure-sensitive circuit interrupters. The circuit interrupter's purpose is to safely remove the capacitor from service at end-of-life or under heavy fault conditions and still maintain case integrity. Aerovox low-voltage capacitor cells are listed for use with or without fuses at 10,000 amps available fault current (AFC rating).

Self-healing technology: in case of an overload, the self-healing properties of the low-loss metallized polypropylene will prevent permanent dielectric breakdown.

Mounting Orientation

All Aerovox power factor correction capacitor cells can be mounted in a vertical position with the terminals facing up or horizontally. The units should not be mounted upside down. For proper operation of the pressure interrupter, capacitors mounted in banks must have enough space between them to allow for heat ventilation and swelling. In cases where brackets or mounting straps are used, there should only be enough pressure on the unit to hold it in place.

Suggested Mounting Clearances

	Side to Side Clearance	Clearance above Terminals
AMP0/EPFC	0.5"	1.0"
MMP0-LV	1.5"	1.0"
MMP0-MV	1.5"	3.0"

Part Numbering System

Aerovox's part numbering system is a descriptive part number made up of several different components such as KVAR, voltage rating, etc. The descriptors are explained below using AMP00125F33S as a representative part number.

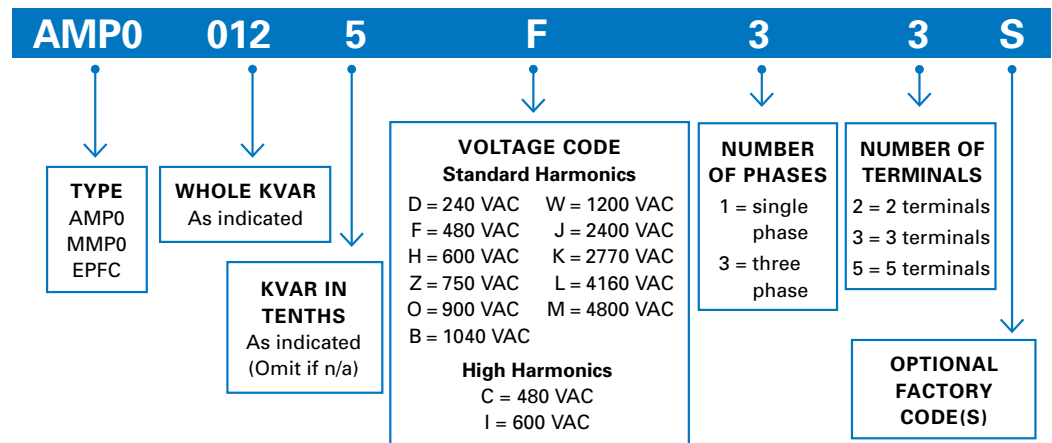

Power Factor Correction Capacitors

SINGLE- AND THREE-PHASE PFC CAPACITORS FOR HIGH RELIABILITY APPLICATIONS

Type AMP0 Capacitor Cells, 240 to 600 VAC, Three-Phase and Single-Phase Reactive Power Compensation Ratings

KVAR RATING	AEROVOX P/N	NOMINAL CURRENT (A _{RMS})	C ₁ NOMINAL CAPACITANCE (µF)	CAN SIZE W x L x H (in)	APPROX WEIGHT (lbs)
240 VAC, 60 Hz, 3 Phase, Delta Connection					
0.5	AMP00005D35	1.2	23.0	2.88 x 4.56 x 3.06	1.4
1	AMP0001D35	2.4	46.1	2.88 x 4.56 x 3.06	1.4
1.5	AMP00015D35	3.6	69.1	2.88 x 4.56 x 3.50	1.7
2	AMP0002D35	4.8	92.1	2.88 x 4.56 x 4.50	1.9
2.5	AMP00025D35	6.0	115.1	2.88 x 4.56 x 4.50	2.2
3	AMP0003D35	7.2	138.2	2.88 x 4.56 x 5.00	2.4
4	AMP0004D35	9.6	184.2	2.88 x 4.56 x 6.00	2.5
5	AMP0005D35	12.0	230.3	2.88 x 4.56 x 6.75	3.0
6	AMP0006D35	14.4	276.3	2.88 x 4.56 x 6.75	3.0
7.5	AMP00075D35	18.0	345.4	2.88 x 4.56 x 7.56	3.7
10	AMP0010D33S	24.1	460.4	3.75 x 4.56 x 8.63	5.2

480 VAC, 60 Hz, 3 Phase, Delta Connection

0.5	AMP00005F35	0.6	5.8	2.88 x 4.56 x 3.06	1.4
1	AMP0001F35	1.2	11.5	2.88 x 4.56 x 3.06	1.4
1.5	AMP00015F35	1.8	17.3	2.88 x 4.56 x 3.06	1.4
2	AMP0002F35	2.4	23.0	2.88 x 4.56 x 3.50	1.8
2.5	AMP00025F35	3.0	28.8	2.88 x 4.56 x 4.00	1.9
3	AMP0003F35	3.6	34.5	2.88 x 4.56 x 4.00	1.9
4	AMP0004F35	4.8	46.1	2.88 x 4.56 x 4.50	2.2
5	AMP0005F35	6.0	57.6	2.88 x 4.56 x 5.00	2.4
6	AMP0006F35	7.2	69.1	2.88 x 4.56 x 5.25	2.5
7.5	AMP00075F35	9.0	86.3	2.88 x 4.56 x 6.00	2.8
10	AMP0010F35	12.0	115.1	2.88 x 4.56 x 6.75	3.2
12.5	AMP00125F35	15.0	143.9	2.88 x 4.56 x 7.38	3.5
15	AMP0015F35	18.0	172.7	2.88 x 4.56 x 8.13	3.7
15	AMP0015F33S	18.0	172.7	3.75 x 4.56 x 7.00	4.3
16.7	AMP00167F33S	20.1	191.9	3.75 x 4.56 x 7.00	4.3
17.5	AMP00175F33S	21.0	201.5	3.75 x 4.56 x 6.75	4.1

Power Factor Correction Capacitors

SINGLE- AND THREE-PHASE PFC CAPACITORS
FOR HIGH RELIABILITY APPLICATIONS

Type AMP0 Capacitor Cells, 240 to 600 VAC, Three-Phase and Single-Phase (cont.)

Reactive Power Compensation Ratings

KVAR RATING	AEROVOX P/N	NOMINAL CURRENT (A _{RMS})	C ₁ NOMINAL CAPACITANCE (μF)	CAN SIZE W x L x H (in)	APPROX WEIGHT (lbs)
20	AMP0020F33S	24.1	230.3	3.75 x 4.56 x 7.00	4.3
22.5	AMP00225F33S	27.1	259.0	3.75 x 4.56 x 8.63	5.2
25	AMP0025F33S	30.1	287.8	3.75 x 4.56 x 9.00	5.5

480 VAC, High Harmonic Applications, 3 Phase, Delta Connection

7.5	AMP00075C35	9.0	86.3	2.88 x 4.56 x 6.75	3.2
10.0	AMP0010C35	12.0	115.1	2.88 x 4.56 x 8.13	3.7
12.5	AMP00125C33S	15.0	143.9	3.75 x 4.56 x 7.00	4.3
15	AMP0015C33S	18.0	172.7	3.75 x 4.56 x 10.50	5.9
16.7	AMP00167C33S	20.1	191.9	3.75 x 4.56 x 10.50	6.0
17.5	AMP00175C33S	21.1	201.5	3.75 x 4.56 x 10.50	6.1
20	AMP0020C33S	24.1	230.3	3.75 x 4.56 x 10.50	6.3

600 VAC, 60 Hz, 3 Phase, Delta Connection

1.0	AMP0001H35	1.0	7.4	2.88 x 4.56 x 3.06	1.4
1.5	AMP00015H35	1.4	11.1	2.88 x 4.56 x 3.06	1.4
2.0	AMP0002H35	1.9	14.7	2.88 x 4.56 x 3.50	1.8
2.5	AMP00025H35	2.4	18.4	2.88 x 4.56 x 4.00	1.9
3.0	AMP0003H35	2.9	22.1	2.88 x 4.56 x 4.00	1.9
4.0	AMP0004H35	3.8	29.5	2.88 x 4.56 x 4.50	2.2
5.0	AMP0005H35	4.8	36.8	2.88 x 4.56 x 5.00	2.4
6.0	AMP0006H35	5.8	44.2	2.88 x 4.56 x 6.00	2.5
7.5	AMP00075H35	7.2	55.3	2.88 x 4.56 x 6.00	2.8
10.0	AMP0010H35	9.6	73.7	2.88 x 4.56 x 6.75	3.2
12.5	AMP00125H35	12.0	92.1	2.88 x 4.56 x 7.38	3.5
15.0	AMP0015H35	14.4	110.5	2.88 x 4.56 x 8.13	3.9
16.7	AMP00167H33S	16.1	122.8	3.75 x 4.56 x 6.75	4.1
17.5	AMP00175H33S	16.8	128.9	3.75 x 4.56 x 6.75	4.1
20.0	AMP0020H33S	19.2	147.4	3.75 x 4.56 x 7.00	4.4
22.5	AMP00225H33S	21.7	165.8	3.75 x 4.56 x 8.63	5.4
25.0	AMP00225H33S	24.1	184.2	3.75 x 4.56 x 9.00	5.7

Power Factor Correction Capacitors

SINGLE- AND THREE-PHASE PFC CAPACITORS
FOR HIGH RELIABILITY APPLICATIONS

Type AMP0 Capacitor Cells, 240 to 600 VAC, Three-Phase and Single-Phase

Reactive Power Compensation Ratings

KVAR RATING	AEROVOX P/N	NOMINAL CURRENT (A _{RMS})	C ₁ NOMINAL CAPACITANCE (μF)	CAN SIZE W x L x H (in)	APPROX WEIGHT (lbs)
10.5	AMP00101I33S	9.6	73.7	3.75 x 4.56 x 6.00	3.5
12.5	AMP00125I33S	12.0	92.1	3.75 x 4.56 x 8.25	4.7
15.0	AMP0015I33S	14.4	110.5	3.75 x 4.56 x 9.00	5.2
16.7	AMP00165I33S	16.1	123.1	3.75 x 4.56 x 9.00	5.2
17.5	AMP00175I33S	16.8	128.9	3.75 x 4.56 x 10.50	5.5
20.0	AMP00201I33S	19.2	147.4	3.75 x 4.56 x 10.50	5.5

600 VAC, High Harmonic Applications, 3 Phase, Delta Connection

10.5	AMP00101I33S	9.6	73.7	3.75 x 4.56 x 6.00	3.5
12.5	AMP00125I33S	12.0	92.1	3.75 x 4.56 x 8.25	4.7
15.0	AMP0015I33S	14.4	110.5	3.75 x 4.56 x 9.00	5.2
16.7	AMP00165I33S	16.1	123.1	3.75 x 4.56 x 9.00	5.2
17.5	AMP00175I33S	16.8	128.9	3.75 x 4.56 x 10.50	5.5
20.0	AMP00201I33S	19.2	147.4	3.75 x 4.56 x 10.50	5.5

Outline Drawings

AMP0: Suffix "35"

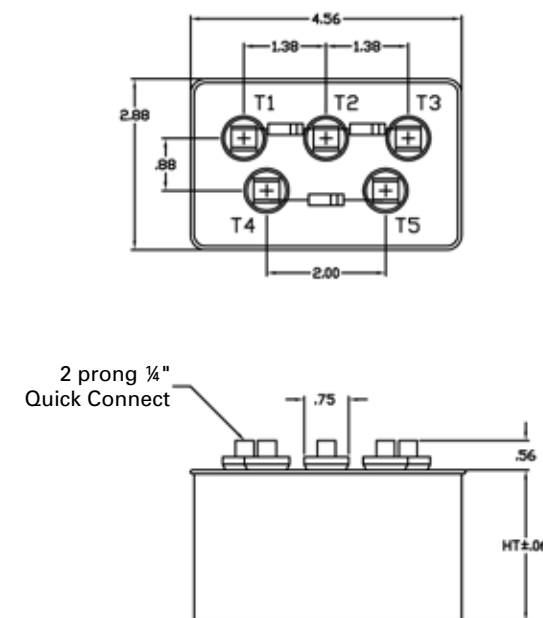

AMP0: Suffix "33S"

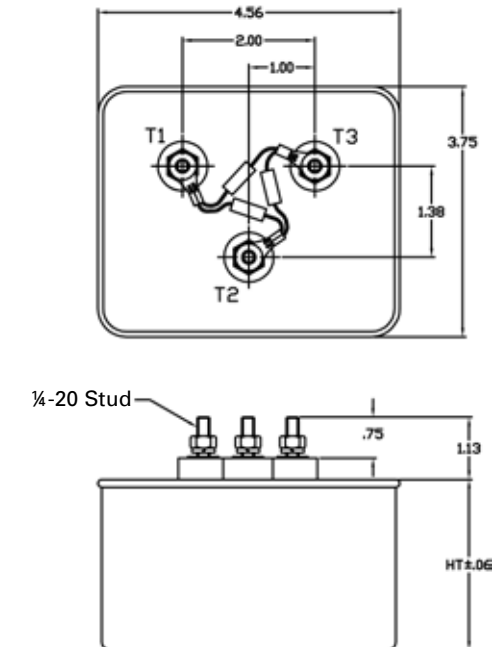

Power Factor Correction Capacitors

SINGLE- AND THREE-PHASE PFC CAPACITORS
FOR HIGH RELIABILITY APPLICATIONS

Type MMP0 Capacitor Cells, 240 to 600 VAC, Three-Phase and Single-Phase Reactive Power Compensation Ratings

KVAR RATING	AEROVOX P/N	NOMINAL CURRENT (A _{RMS})	C ₁ NOMINAL CAPACITANCE (μF)	CAN SIZE W x L x H (in)	APPROX WEIGHT (lbs)
240 VAC, 60 Hz, 3 Phase, Delta Connection					
20	MMP0020D33	48.1	921.0	3.75 x 13.5 x 11.5	26.1
25	MMP0025D33	60.1	1151.3	3.75 x 13.5 x 13.5	31.3
30	MMP0030D33	72.2	1381.6	3.75 x 13.5 x 15.5	36.5
480 VAC, 60 Hz, 3 Phase, Delta Connection					
25	MMP0025F33	30.1	287.8	3.75 x 13.5 x 8.5	21.4
30	MMP0030F33	36.1	345.4	3.75 x 13.5 x 9.5	23.5
35	MMP0035F33	42.1	403.0	3.75 x 13.5 x 11.5	28.1
40	MMP0040F33	48.1	460.5	3.75 x 13.5 x 11.5	28.3
45	MMP0045F33	54.1	518.1	3.75 x 13.5 x 13.5	32.2
50	MMP0050F33	60.1	575.6	3.75 x 13.5 x 13.5	32.3
60	MMP0060F33	72.2	690.8	3.75 x 13.5 x 15.5	36.4
75	MMP0075F33	90.2	863.5	3.75 x 13.5 x 18.5	43.1
80	MMP0080F33	96.2	921.0	3.75 x 13.5 x 19.5	44.6
90	MMP0090F33	108.3	1036.2	3.75 x 13.5 x 20.5	45.9
100	MMP0100F33	120.3	1151.3	3.75 x 13.5 x 24.0	55.3
480 VAC, High Harmonic Applications, 3 Phase, Delta Connection					
25	MMP0025C33	30.1	287.8	3.75 x 13.5 x 8.5	21.4
50	MMP0050C33	60.1	575.6	3.75 x 13.5 x 13.5	32.3
75	MMP0075C33	90.2	863.5	3.75 x 13.5 x 18.5	43.1
100	MMP0100C33	120.3	1151.3	3.75 x 13.5 x 24.0	55.3
600 VAC, High Harmonic Applications, 3 Phase, Delta Connection					
25	MMP0025I33	24.1	184.2	3.75 x 13.5 x 8.5	21.4
30	MMP0030I33	28.9	221.0	3.75 x 13.5 x 9.5	23.5
35	MMP0035I33	33.7	275.9	3.75 x 13.5 x 11.5	28.1
40	MMP0040I33	38.5	294.7	3.75 x 13.5 x 11.5	28.3
45	MMP0045I33	43.3	331.6	3.75 x 13.5 x 13.5	32.2
50	MMP0050I33	48.1	368.4	3.75 x 13.5 x 13.5	32.3
60	MMP0060I33	57.7	442.1	3.75 x 13.5 x 15.5	36.4
75	MMP0075I33	72.2	552.6	3.75 x 13.5 x 18.5	43.1
80	MMP0080I33	77.0	589.5	3.75 x 13.5 x 19.5	44.6
90	MMP0090I33	86.6	663.1	3.75 x 13.5 x 20.5	45.9
100	MMP0100I33	96.2	736.8	3.75 x 13.5 x 24.0	55.3

Power Factor Correction Capacitors

SINGLE- AND THREE-PHASE PFC CAPACITORS
FOR HIGH RELIABILITY APPLICATIONS

Type MMP0 Capacitor Cells, 750 VAC and 900 VAC, Three-Phase and Single-Phase Reactive Power Compensation Ratings

KVAR RATING	AEROVOX P/N	NOMINAL CURRENT (A _{RMS})	C ₁ NOMINAL CAPACITANCE (μF)	CAN SIZE W x L x H (in)	APPROX WEIGHT (lbs)
750 VAC, 60 Hz, 3 Phase, "WYE" Connection					
50	MMP0050Z33	38.5	707.4	3.75 x 13.5 x 12.5	32.4
75	MMP0075Z33	57.7	1061	3.75 x 13.5 x 18.5	46.5
100	MMP0100Z33	77	1414.7	3.75 x 13.5 x 24.0	55.3
900 VAC, 60 Hz, 3 Phase, "WYE" Connection					
50	MMP0050O33	32.1	491.2	3.75 x 13.5 x 12.5	32.4
75	MMP0075O33	48.1	736.8	3.75 x 13.5 x 17.0	44.8
100	MMP0100O33	64.2	982.4	3.75 x 13.5 x 20.5	49.6

Type MMP0 Capacitor Cells, 1040 VAC to 4800 VAC, Three-Phase and Single-Phase Reactive Power Compensation Ratings

KVAR RATING	AEROVOX P/N	NOMINAL CURRENT (A _{RMS})	C ₁ NOMINAL CAPACITANCE (μF)	CAN SIZE W x L x H (in)	APPROX WEIGHT (lbs)
1040 VAC, 60 Hz, 3 Phase, Delta Connection					
25	MMP0025B33	13.9	61.3	5.63 x 13.5 x 6.0	20.5
50	MMP0050B33	27.8	122.6	5.63 x 13.5 x 7.5	25.7
75	MMP0075B33	41.6	183.9	5.63 x 13.5 x 10.0	34.2
100	MMP0100B33	55.6	245.2	5.63 x 13.5 x 11.5	39.3
125	MMP0125B33	69.4	306.6	5.63 x 13.5 x 13.0	44.5
150	MMP0150B33	83.3	367.9	5.63 x 13.5 x 15.0	51.3
175	MMP0175B33	97.2	429.2	5.63 x 13.5 x 17.5	59.9
200	MMP0200B33	111.0	490.5	5.63 x 13.5 x 20.0	68.4
1200 VAC, 60 Hz, 3 Phase, Delta Connection					
25	MMP0025W33	12.0	46.1	5.63 x 13.5 x 6.0	20.5
50	MMP0050W33	24.1	92.1	5.63 x 13.5 x 9.0	30.8
75	MMP0075W33	36.1	138.2	5.63 x 13.5 x 10.0	34.2
100	MMP0100W33	48.1	184.2	5.63 x 13.5 x 11.5	39.3
125	MMP0125W33	60.1	230.3	5.63 x 13.5 x 14.0	47.9
150	MMP0150W33	72.2	276.3	5.63 x 13.5 x 15.0	51.3
175	MMP0175W33	84.2	322.4	5.63 x 13.5 x 17.5	59.9
200	MMP0200W33	96.2	368.4	5.63 x 13.5 x 19.0	65.0

Power Factor Correction Capacitors

SINGLE- AND THREE-PHASE PFC CAPACITORS
FOR HIGH RELIABILITY APPLICATIONS

Type MMP0 Capacitor Cells, 1040 VAC to 4800 VAC, Three-Phase and Single-Phase (cont.)

Reactive Power Compensation Ratings

KVAR RATING	AEROVOX P/N	NOMINAL CURRENT (A _{RMS})	C, NOMINAL CAPACITANCE (μF)	CAN SIZE W x L x H (in)	APPROX WEIGHT (lbs)
2400 VAC, 60 Hz, 3 Phase, Delta Connection					
25	MMP0025J33	6.0	11.5	5.63 x 13.5 x 6.0	20.5
50	MMP0050J33	12.0	23.0	5.63 x 13.5 x 7.5	25.7
75	MMP0075J33	18.0	34.5	5.63 x 13.5 x 10.0	34.2
100	MMP0100J33	24.1	46.1	5.63 x 13.5 x 11.5	39.3
125	MMP0125J33	30.1	57.6	5.63 x 13.5 x 14.0	47.9
150	MMP0150J33	36.1	69.1	5.63 x 13.5 x 16.0	54.7
175	MMP0175J33	42.1	80.6	5.63 x 13.5 x 17.5	59.9
200	MMP0200J33	48.1	92.1	5.63 x 13.5 x 19.0	65.0
2770 VAC, 60 Hz, 3 Phase, Delta Connection					
25	MMP0025K33	5.2	8.6	5.63 x 13.5 x 7.5	25.7
50	MMP0050K33	10.4	17.3	5.63 x 13.5 x 9.0	30.8
75	MMP0075K33	15.6	25.9	5.63 x 13.5 x 11.5	39.3
100	MMP0100K33	20.8	34.6	5.63 x 13.5 x 11.5	39.3
125	MMP0125K33	26.1	73.2	5.63 x 13.5 x 16.0	54.7
150	MMP0150K33	31.3	51.9	5.63 x 13.5 x 17.5	59.9
175	MMP0175K33	36.5	60.5	5.63 x 13.5 x 19.0	65.0
200	MMP0200K33	41.7	69.1	5.63 x 13.5 x 20.0	68.4
4160 VAC, 60 Hz, 3 Phase, Delta Connection					
25	MMP0025L33	3.5	3.8	5.63 x 13.5 x 7.5	25.7
50	MMP0050L33	7.0	7.7	5.63 x 13.5 x 9.0	30.8
75	MMP0075L33	10.4	11.5	5.63 x 13.5 x 11.5	39.3
100	MMP0100L33	13.9	15.3	5.63 x 13.5 x 11.5	39.3
125	MMP0125L33	17.4	19.2	5.63 x 13.5 x 16.0	54.7
150	MMP0150L33	20.8	23.0	5.63 x 13.5 x 17.5	59.9
175	MMP0175L33	24.3	26.8	5.63 x 13.5 x 19.0	65.0
200	MMP0200L33	27.8	30.7	5.63 x 13.5 x 20.0	68.4
4800 VAC, 60 Hz, 3 Phase, Delta Connection					
25	MMP0025M33	3.0	2.9	5.63 x 13.5 x 7.5	25.7
50	MMP0050M33	6.0	4.8	5.63 x 13.5 x 9.0	30.8
75	MMP0075M33	9.0	8.6	5.63 x 13.5 x 10.0	34.2
100	MMP0100M33	12.0	11.5	5.63 x 13.5 x 11.5	39.3
125	MMP0125M33	15.0	14.4	5.63 x 13.5 x 16.0	54.7
150	MMP0150M33	18.0	17.3	5.63 x 13.5 x 17.5	59.9
175	MMP0175M33	21.1	20.1	5.63 x 13.5 x 17.5	59.9
200	MMP0200M33	24.1	23.0	5.63 x 13.5 x 20.0	68.4

Power Factor Correction Capacitors

SINGLE- AND THREE-PHASE PFC CAPACITORS
FOR HIGH RELIABILITY APPLICATIONS

Outline Drawings

MMP0: 240, 480, 600, 750 & 900 VAC

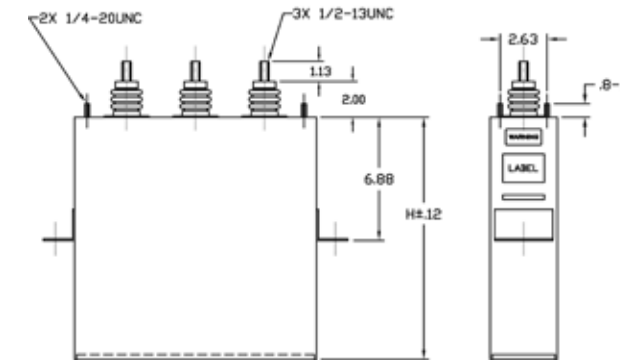
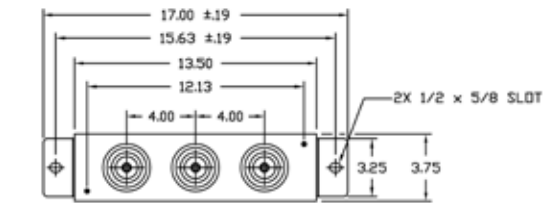

MMP0: 1040 to 4800 VAC

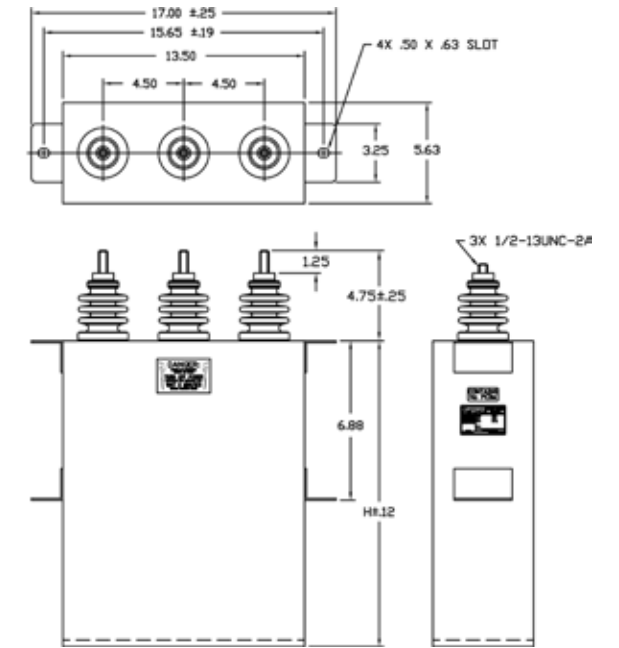

Power Factor Correction Capacitors

SINGLE- AND THREE-PHASE PFC CAPACITORS
FOR HIGH RELIABILITY APPLICATIONS

Type EPFC Capacitor Cells

KVAR RATING	AEROVOX P/N	NOMINAL CURRENT (A _{RMS})	C, NOMINAL CAPACITANCE (μF)	DIMENSIONS D x H (mm)	APPROX WEIGHT (kg)
-------------	-------------	-------------------------------------	-----------------------------	-----------------------	--------------------

240 VAC, 60 Hz, 3 Phase, Delta Connection

0.5	EPFC0005D33N	1.2	23.0	76 x 70	0.48
1	EPFC001D33N	2.4	46.1	76 x 75	0.50
2	EPFC002D33N	4.8	92.1	76 x 140	0.78
2.5	EPFC0025D33N	6.0	115.1	76 x 140	0.78
3	EPFC003D33N	7.2	138.2	76 x 140	0.78
4	EPFC004D33N	9.6	184.2	86 x 115	0.90
5	EPFC005D33N	12.0	230.3	86 x 170	1.20
6	EPFC006D33N	14.4	276.3	86 x 170	1.20
7.5	EPFC0075D33N	18.0	345.4	86 x 170	1.20
10	EPFC010D33N	24.1	460.4	86 x 200	1.35

480 VAC, 60 Hz, 3 Phase, Delta Connection

2	EPFC002F33N	2.4	23.0	86 x 70	0.60
7.5	EPFC075F33N	9.0	86.3	86 x 170	1.15
10	EPFC010F33N	12.0	115.1	86 x 170	1.15
12.5	EPFC0125F33N	15.0	143.9	86 x 170	1.15
15	EPFC015F33N	18.0	172.7	86 x 200	1.35
16.7	EPFC0167F33N	20.0	191.9	86 x 215	1.45
17.5	EPFC0175F33N	21.0	201.8	86 x 245	1.60
20	EPFC020F33N	24.0	230.3	86 x 245	1.60
22.5	EPFC0225F33N	27.0	259.0	86 x 275	1.75
25	EPFC025F33N	30.0	287.8	86 x 275	1.75
30	EPFC030F33N	36.0	345.6	116 x 275	3.15
35	EPFC035F33N	42.1	403.2	116 x 305	3.45
40	EPFC040F33N	48.1	460.8	116 x 335	3.70

600 VAC, 60 Hz, 3 Phase, Delta Connection

10	EPFC010H33N	9.6	73.7	86 x 170	1.15
12.5	EPFC0125H33N	12.0	92.1	86 x 170	1.15
15	EPFC015H33N	14.4	110.5	86 x 200	1.35
16.7	EPFC0167H33N	16.0	122.8	86 x 215	1.45
17.5	EPFC0175H33N	16.8	128.9	86 x 215	1.45
20	EPFC020H33N	19.2	147.4	86 x 245	1.60
22.5	EPFC0225H33N	21.6	165.8	86 x 275	1.75
25	EPFC025H33N	24.0	184.2	86 x 275	1.75
30	EPFC030H33N	28.8	219.9	116 x 275	2.95
35	EPFC035H33N	33.6	258.0	116 x 305	3.25
40	EPFC040H33N	38.4	294.9	116 x 335	3.70

Power Factor Correction Capacitors

SINGLE- AND THREE-PHASE PFC CAPACITORS
FOR HIGH RELIABILITY APPLICATIONS

KVAR RATING	AEROVOX P/N	NOMINAL CURRENT (A _{RMS})	C, NOMINAL CAPACITANCE (μF)	DIMENSIONS D x H (mm)	APPROX WEIGHT (kg)
-------------	-------------	-------------------------------------	-----------------------------	-----------------------	--------------------

480 VAC, 60 Hz, High Harmonic Applications, 3 Phase, Delta Connection

12.5	EPFC0125C33N	15.0	143.9	86 x 245	1.60
15	EPFC015C33N	18.0	172.7	86 x 275	1.75
16.7	EPFC0167C33N	20.0	191.9	86 x 305	1.90
17.5	EPFC0175C33N	21.0	201.5	86 x 305	1.90
20	EPFC020C33N	24.0	230.3	86 x 335	2.05

600 VAC, 60 Hz, High Harmonic Applications, 3 Phase, Delta Connection

10	EPFC010I33N	9.6	73.7	86 x 200	1.35
12.5	EPFC0125I33N	12.0	92.1	86 x 245	1.60
15	EPFC015I33N	14.4	110.5	86 x 245	1.60
16.7	EPFC0167I33N	16.0	122.8	86 x 275	1.75
17.5	EPFC0175I33N	16.8	128.9	86 x 275	1.75
20	EPFC020I33N	19.2	147.4	86 x 305	1.90

Outline Drawing

EPFC: 240 to 600 VAC

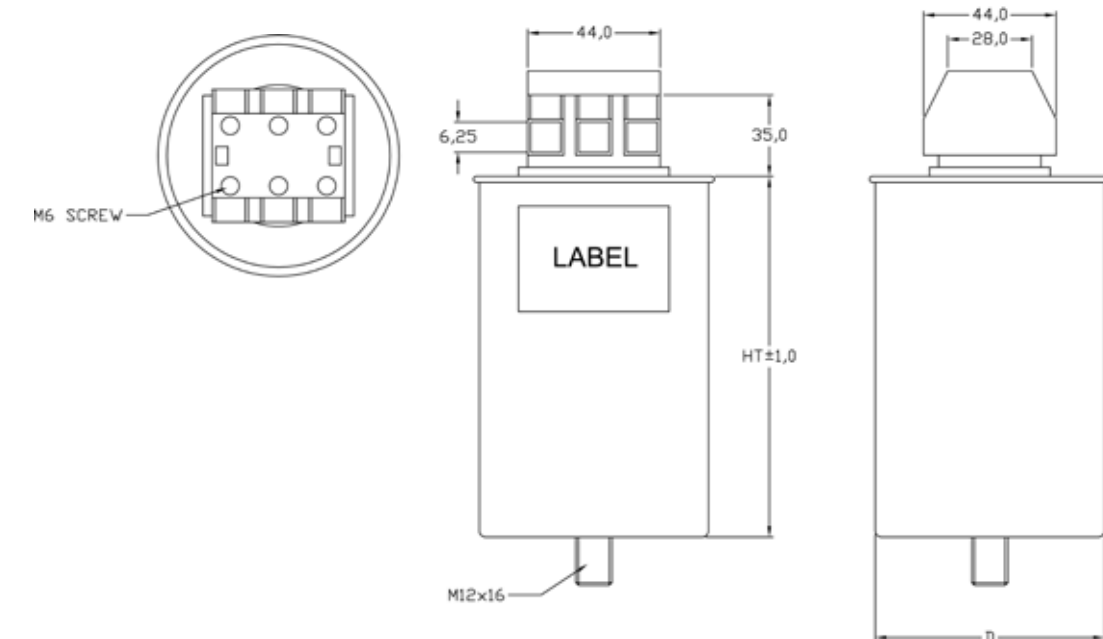

Power Factor Correction Capacitors

SINGLE- AND THREE-PHASE PFC CAPACITORS
FOR HIGH RELIABILITY APPLICATIONS

Equations for Power Factor Correction and Harmonic Distortion (Balanced Phase Loads)

Capacitors in Parallel

$$C_T = C_1 + C_2 + C_3 + \dots + C_n = \sum_{i=1}^n C_i$$

Capacitors in Series

$$\frac{1}{C_T} = \frac{1}{C_1} + \frac{1}{C_2} + \frac{1}{C_3} + \dots + \frac{1}{C_n} = \sum_{i=1}^n \frac{1}{C_i}$$

$$DF = \tan(\delta) = \frac{ESR}{X_c} = (2\pi f)(C)(ESR)$$

$$\text{Power Loss} = (2\pi f)(C \times V^2)(DF)$$

$$X_c = \frac{1}{(2\pi f)C}$$

$$C_T = \frac{KVAR \times 10^{-3}}{(2\pi f)(KV)^2}$$

$$KW \text{ (Motor Input)} = \frac{hp \times 0.746}{\%Eff}$$

$$KVA = \frac{KW}{PF} = \sqrt{(KW)^2 + (KVAR)^2}$$

$$KVAR = \frac{2\pi \times f \times C \times (KV)^2}{10^{-3}}$$

$$KVAR_E = KVAR_R \times \left[\frac{V_A}{V_R} \right]^2 \times \left[\frac{f_A}{f_R} \right]$$

$$KVAR = \frac{hp \times 0.746}{\eta} \left[\sqrt{\frac{1 - PF_0^2}{PF_0^2}} - \sqrt{\frac{1 - PF_T^2}{PF_T^2}} \right]$$

$$KVA = \frac{V_L \times I_L}{1000} \quad \text{Single-Phase}$$

$$KVA = \frac{\sqrt{3} \times V_L \times I_L}{1000} \quad \text{Three-Phase}$$

$$I_{RMS} = \sqrt{I_1^2 + \sum_{h=2}^{\infty} I_h^2}$$

Legend

K	1000	V _A	Applied line Voltage
W	Watts	V _R	Rated line voltage
V	Volts	f _A	Applied frequency
A	Amperes	f _R	Rated frequency
hp	horsepower	η	Motor efficiency
C	Capacitance (Farads)	PF ₀	Initial Power Factor
PF	Power Factor	PF _T	Target Power Factor
KW	Working Power (1000 Watts)	I _{RMS}	Root-mean-square value of current
KVA	Total Power (1000 Volt-Amperes)	I ₁	Current at fundamental frequency
KVAR	Reactive Power (1000 Volt-Amperes Reactive)	I _h	Harmonic current of order h
δ	Loss Angle	C _T	Total capacitance (Farads)
V _L	Line Voltage	X _c	Capacitor reactance
I _L	Line current	I _{ph}	Phase current
f	Frequency	DF	Dissipation Factor
KVAR _E	Effective KVAR	ESR	Equivalent Series Resistances (Ohms)
KVAR _R	Rated KVAR		

Power Factor Correction Capacitors

SINGLE- AND THREE-PHASE PFC CAPACITORS
FOR HIGH RELIABILITY APPLICATIONS

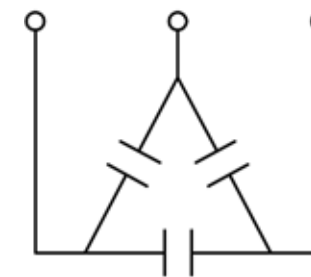

Delta Connection

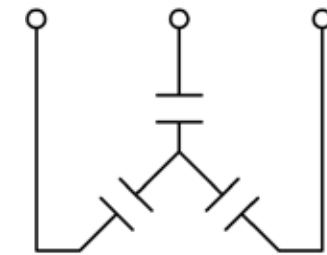

Wye Connection

About Aerovox

Aerovox is a leading manufacturer of capacitors for industrial, medical and specialized applications, with world-class design, manufacturing and testing facilities in New Bedford, MA. Global manufacturing facilities in China and India enable quick turn-around for shipping and delivery worldwide.

Aerovox capacitors are among the world's most reliable components. Our extensive custom design and development capabilities coupled with broad, standardized product offerings allow us to provide intelligent capacitor solutions that meet or exceed customers' application requirements.

Our aim is to be the best and most sought after provider of capacitor solutions for specialty markets in the world by achieving the highest level of customer satisfaction with extraordinary emphasis on the creation of value and speed to market.

Aerovox[®]

Aerovox Corp.
167 John Vertente Blvd.
New Bedford, MA 02745
Tel: +1-508-994-9661
Fax: +1-508-995-3000
www.aerovox.com

Aerovox China
28 Wangehun Rd
Ningbo, Zhejiang
China

Aerovox India
Plot # 30 to 33
Hardware Park
Imarat Kancha
Raviryal Village
Maheshwaram Mandal
R R District – 500 066
Andhra Pradesh State
India

Copyright 2011, Aerovox Corp. All rights reserved.

Aerovox is a registered trademark and AeroPower is a trademark of Aerovox Corp.

PF01110 Printed in the USA